

**DISTINTA DELLE PARTI COSTITUENTI LE POMPE ROTATIVE VOLUMETRICHE SERIE "V"**  
**SPARE PARTS LIST FOR "V" SERIES POSITIVE-DISPLACEMENT ROTARY PUMPS**  
**LISTE DES PIECES DE RECHANGE POUR POMPES ROTATIVES VOLUMETRIQUES SERIE "V"**  
**ERSATZTEILLISTE FÜR SELBSTANSAUGENDE INNENZAHNRADPUMPEN SERIE "V"**

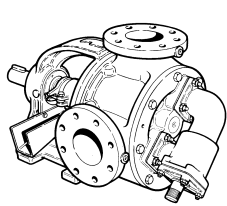

V100-2 SP Code 1001 0394  
 V100-2 SPG Code 1001 0400  
 V100-2 SPK Code 1001 0443

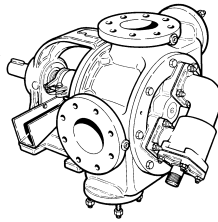

V100-2 SPHTR Code 1001 0405

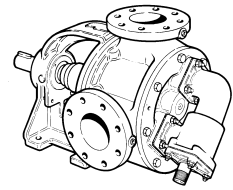

V100-2 ST4W Code 1001 0413  
 V100-2 ST4BS Code 1001 0409  
 V100-2 ST4K Code 1001 0446

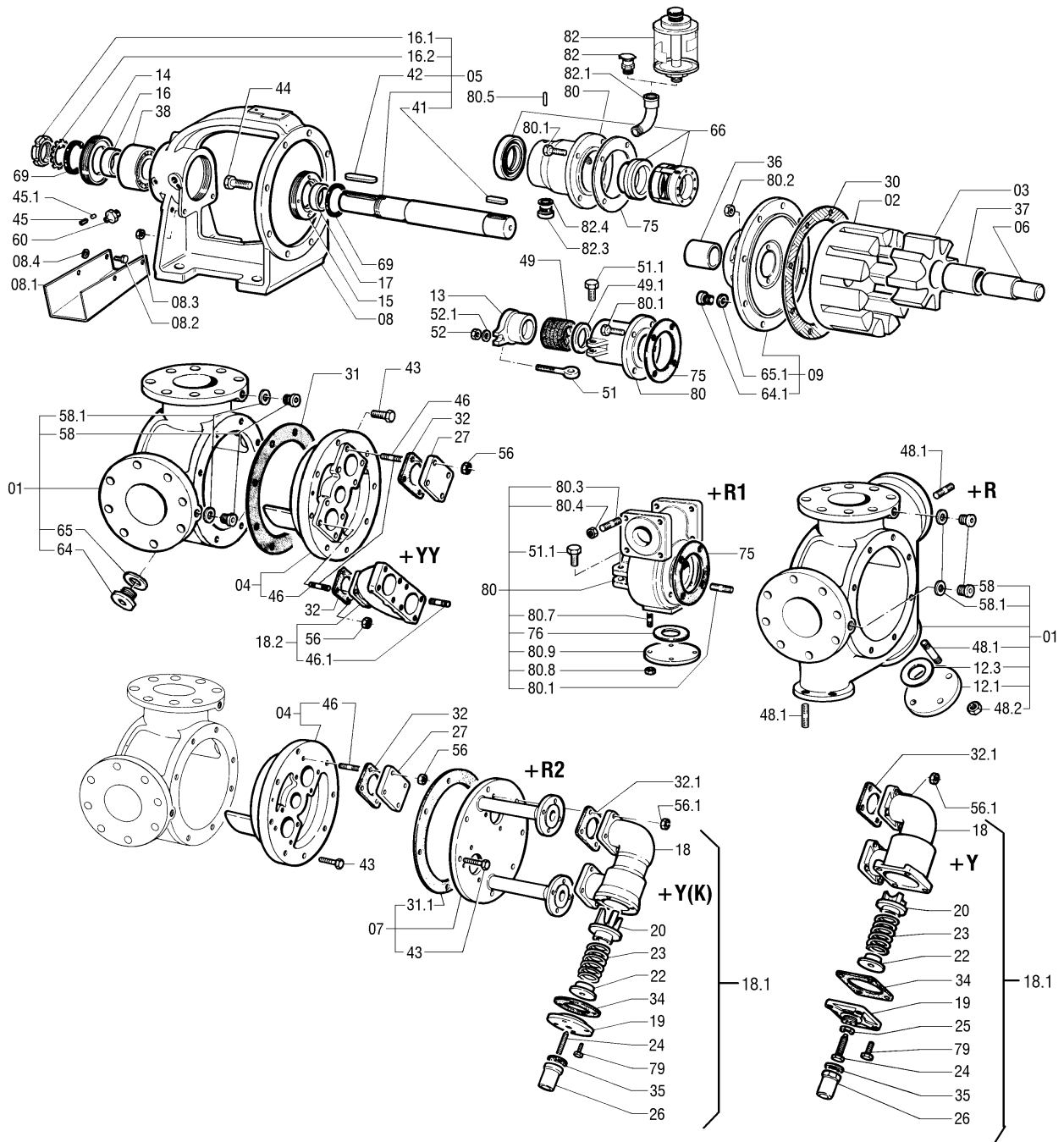

Rif. N°. Pos. Nr. Ref. no. Ref. N°.	Quant.	Denominazione	Part name	Den. Comm. Type	Mat.*	Codice Vecchio Old Part.N°	Codice Nuovo New Part.N°	V100-2SP	V100-2 SPG	V100-2 SPHTR	V100-2ST4W	V100-2 ST4BS	V100-2 SPK	V100-2 ST4K		
01	1	Corpo (1)	Casing (1)		GS	5319 3031	1001 9366	○	○		○	○				
		(2)	(2)		GS	5319 3032	1000 8057	①	①	○	①	①				
		(1)	(1)		K	5319 5008	1000 8067						○	○		
02	1	Rotore	Rotor		GS	3765 3019	1000 6597	○	○	○	○	○				
					K	3765 5008	1000 6669							○	○	
03	1	Ruota oziosa	Idler		GS	3780 3025	1000 6746	○	○	○	○					
					GSH	3780 3030	1000 6750						○			
					K	3780 5010	1000 6823							○	○	
04	1	Coperchio (3)	Cover (3)		GS	5270 3015	1000 8015	○	○	○	○	○				
					K	5270 5009	1001 9367							○	○	
					K		1001 5929								③	③
					K		1001 5929								④	④
05	1	Albero (4)	Shaft (4)	D.55	SH	5032 4014	1000 7620	○	○	○	○					
					K5	5032 5033	1000 7630						○	○	○	
06	1	Perno	Idler pin	D.60	T	3540 4019	1000 5900	○	○		○					
					T2	3540 4020	1000 5901			○						
					K9	3540 5041	1000 5941						○	○	○	
07	1	Camera di prerisc. (5)	Heating jacket (5)		S+K	5135 4009	1001 9368						③	③		
						5135 4011	1001 9369							④	④	
08	1	Supporto	Bearing housing		G	3872 3016	1000 6892	○	○	○	○	○	○	○		
08.1	1	Colatoio	Drip tray		S	3435 4003	1000 5479	○	○	○						
					K	3435 5003	1000 5485							○		
08.2	2	Vite	Screw	M 8 x 20 DIN 933	S	1478 4010	1000 1937	○	○	○						
					K	1478 5008	1000 2027								○	
08.3	2	Dado	Nut	M 8 DIN 934	S	1420 4004	1000 1420	○	○	○						
					K	1420 5004	1000 1435								○	
08.4	2	Rondella	Washer	M 8 DIN 125 A	S	1450 4003	1000 1689	○	○	○						
					K	1450 5016	1000 1718								○	
09	1	Flangia supporto (6)	Rear cover (6)		GS	5375 3016	1000 8105	○	○	○						
					GS	3375 3023	1000 5154				○	○				
					K	3375 5016	1000 5175							○		
					K	3375 5028	1000 5180								○	
12.1	1	Flangia	Flange	DN40 PN16 UNI 6093	S	3362 4002	1000 5133			○						
12.3	1	Guarnizione	Gasket	50 x 88 x 2	E3	3450 0254	1000 5593			○						
13	1	Premitreccia	Gland		G	3690 3007	1000 6518	○	○	○						
					K	3690 5006	1000 6527								○	
14	1	Copricuscinetto	Bearing cover		G	3287 3020	1000 4807	○	○		○	○	○	○		
					G	3287 3021	1000 4808	①	①	○	①	①				
15	1	Copricuscinetto	Bearing cover		G	3287 3022	1000 4809	○	○		○	○	○	○		
					G	3287 3023	1000 4810	①	①	○	①	①				
16	1	Ghiera	Sleeve	50 x 60 x 16	S	3107 4510	1000 4246	○	○	○	○	○	○	○		
16.1	1	Ghiera	Sleeve	M 50 x 1,5	S	1430 4007	1000 1576	○	○	○	○	○	○	○		
16.2	1	Rondella	Washer	MB7 UNI 3073 D.50	S	1452 4003	1000 1722	○	○	○	○	○	○	○		
17	1	Ghiera	Sleeve	50 x 60 x 16	S	3107 4510	1000 4246	○	○	○	○	○	○	○		
18	1	Corpo By-pass	By-pass casing		G	3240 3019	1000 4460	⑥	⑥	⑥	⑥	⑥				
					G	3240 3019	1000 4460	⑦	⑦	⑦	⑦	⑦				
					K	3240 5048	1000 4524							⑥	⑥	
18.1	1	By-pass	By-pass		G	5090 3028	1000 7746	⑥	⑥	⑥	⑥	⑥				
					G	5090 3024	1000 7745	⑦	⑦	⑦	⑦	⑦				
					K	5090 5017	1000 7763							⑥	⑥	
18.2	2	Raccordo doppio (7)	Double manifold (7)		G	5240 3026	1001 9370	⑦	⑦	⑦	⑦	⑦				
19	1	Coperchio By-pass	By-pass cover		G	3240 3004	1000 4450	⑥	⑥	⑥	⑥	⑥				
					G	3240 3004	1000 4450	⑦	⑦	⑦	⑦	⑦				
					K	3240 5053	1000 4528							⑥	⑥	
20	1	Valvola By-pass	By-pass check valve		G	3240 3029	1000 4468	⑥	⑥	⑥	⑥	⑥				
					G	3240 3029	1000 4468	⑦	⑦	⑦	⑦	⑦				
					K	3240 5051	1000 4526							⑥	⑥	

Rif. N°. Pos. Nr. Ref. no. Réf. N°.	Quant.	Denominazione	Part name	Den. Comm. Type	Mat. *	Codice Vecchio Old Part.N°	Codice Nuovo New Part.N°	V100-2SP	V100-2 SPG	V100-2 SPHTR	V100-2ST4W	V100-2 ST4BS	V100-2 SPK	V100-2 ST4K		
22	1	Piattello By-pass	By-pass plate		G	3240 3022	1000 4462	⑥	⑥	⑥	⑥	⑥				
	2				G	3240 3022	1000 4462	⑦	⑦	⑦	⑦	⑦				
	1				K	3240 5056	1000 4529							⑥	⑥	
23	1	Molla By-pass	By-pass spring	D. 8 x 42 x 95 x 15,5	SHT	3495 4020	1000 5789	⑥	⑥	⑥	⑥	⑥				
	2				SHT	3495 4020	1000 5789	⑦	⑦	⑦	⑦	⑦				
	1				K	3495 5006	1000 5798							⑥	⑥	
24	1	Vite By-pass	By-pass screw	M 12 x 50 DIN 914	B	3240 2002	1000 4443	⑥	⑥	⑥	⑥	⑥				
	2				B	3240 2002	1000 4443	⑦	⑦	⑦	⑦	⑦				
	1				K	3240 5032	1000 4513							⑥	⑥	
25	1	Dado	Nut		B	3240 2007	1000 4447	⑥	⑥	⑥	⑥	⑥				
	2				B	3240 2007	1000 4447	⑦	⑦	⑦	⑦	⑦				
26	1	Cappellotto By-pass	By-pass cap		A	3240 1001	1000 4440	⑥	⑥	⑥	⑥	⑥				
	2				A	3240 1001	1000 4440	⑦	⑦	⑦	⑦	⑦				
	1				K	3240 5000	1000 4493							⑥	⑥	
27	2	Flangia By-pass	By-pass flange		G	3362 3006	1000 5127	○	○	○	○	○				
					K	3362 5002	1000 5138							○	○	
30 (**)	1	Guarnizione corpo	Casing gasket	281 x 359 x 0,5												
31 (**)	1	Guarnizione coperchio	Cover gasket	281 x 359 x 0,5												
31.1	1	Guarnizione	Gasket		E3	3450 0054	1000 5516						③	③		
					E3	3450 0055	1001 9371							④	④	
32 (**)	2	Guarnizione	Gasket													
32.1	2	Guarnizione	Gasket		E3	3450 0007	1000 5495	⑥	⑥	⑥	⑥	⑥	⑥	⑥		
					E3	3450 0007	1000 5495	⑦	⑦	⑦	⑦	⑦	⑦			
34	1	Guarnizione	Gasket		E3	3450 0022	1000 5506	⑥	⑥	⑥	⑥	⑥				
					E3	3450 0022	1000 5506	⑦	⑦	⑦	⑦	⑦				
					E3	3450 0100	1000 5520							⑥	⑥	
35	1	Guarnizione cappell.	Cap gasket		E3	3450 0013	1000 5499	⑥	⑥	⑥	⑥	⑥				
					E3	3450 0013	1000 5499	⑦	⑦	⑦	⑦	⑦				
					E3	3450 0029	1000 5512							⑥	⑥	
36	1	Bronzina supporto	Bearing bush	55 x 70 x 80	AD10	3120 2033	1000 4308	○		○	○					
					G	3120 3012	1000 4340		○							
					GR	3120 0026	1000 4273							○	○	○
37	1	Bronzina ruota oziosa	Idler bush	60 x 75 x 100	AD10	3120 2028	1000 4305	○		○	○					
					G	3120 3005	1000 4336		○							
					GR	3120 0017	1000 4267							○	○	○
38	1	Cuscinetto	Ball bearing	3310 HT	S	1418 0091	1000 1388	○	○	○	○	○	○	○		
41	1	Linguetta	Key	14 x 9 x 40 DIN 6885A	S	1434 4024	1000 1602	○	○	○	○					
					K	1434 5012	1000 1628							○	○	○
42	1	Linguetta	Key	14 x 9 x 100 DIN 6885A	S	1434 4023	1000 1601	○	○	○	○	○	○	○		
43 (*)	8	Vite	Screw	M 16 x 40 DIN 933	S			○	○	○	○	○				
					K									○	○	
	8	Prigioniero	Stud	M 16 x 90	K	3975 5030	1001 9372						③	③		
					K	3975 5030	1001 9372						④	④		
44 (*)	8	Vite	Screw	M 16 x 55 DIN 931	S			○	○	○	○	○				
					K									○	○	
45 (*)	2	Vite	Screw	M 6 x 16 DIN913	S			○	○	○	○	○	○	○		
45.1 (*)	2	Pastiglia	Shim	D. 4,8 x 3	R			○	○	○	○	○	○	○		
46 (*)	8	Prigioniero	Stud	M 10 x 25 DIN 938	S			○	○		○	○				
					S						○					
					K										○	○
					K	1468 5004	1000 1846								③	③
					K	1468 5005	1000 1847								④	④
46.1	16	Prigioniero	Stud	M 10 x 30 DIN 938	S	1468 4008	1000 1825	⑦	⑦	⑦	⑦	⑦				
48.1	12	Prigioniero	Stud	M 16 x 35 DIN 938	S	1468 4016	1000 1830	①	①	○	①	①				
48.2	12	Dado	Nut	M 16 DIN 934	S	1420 4009	1000 1425	①	①	○	①	①				
49	1	Baderna	Packing	55 x 75 x 10 x 5	TE	5060 0036	1000 7648	○	○					○		
				55 x 75 x 10 UP3075		5060 0013	1000 7644									

Rif. N°. Pos. Nr. Ref. no. Réf. N°.	Quant.	Denominazione	Part name	Den. Comm. Type	Mat.*	Codice Vecchio Old Part.N°	Codice Nuovo New Part.N°	V100-2SP	V100-2 SPG	V100-2 SPHTR	V100-2ST4W	V100-2 ST4BS	V100-2 SPK	V100-2 ST4K	
49.1	1	Anello	Ring		K	3045 5019	1000 4092	○	○	○			○		
51	2	Tirante	Eyebolt	M 10 x 60 DIN 444B	H	1466 5002	1000 1815	○	○	○			○		
51.1	2	Vite	Screw	M 10 x 30 DIN 933	S	1478 4026	1000 1949			○					
				M 10 x 35 DIN 933	S	1478 4027	1000 1950	○	○						
				M 10 x 30 DIN 933	K	1478 5027	1000 2044						○		
52	2	Dado	Nut	M 10 DIN 934	S	1420 4005	1000 1421	○	○	○					
					K	1420 5006	1000 1437							○	
52.1	2	Rondella	Washer	M 10 DIN 125A	S	1450 4005	1000 1691	○	○	○					
					K	1450 5001	1000 1704							○	
56 (*)	8	Dado	Nut	M 10 DIN 934	S	1420 4005	1000 1421	○	○	○	○	○	○	○	
56.1	8	Dado	Nut	M 10 DIN 934	S	1420 4005	1000 1421	⊗	⊗	⊗	⊗	⊗			
	16				S	1420 4005	1000 1421	⊗	⊗	⊗	⊗	⊗			
	8				K	1420 5006	1000 1437						⊗	⊗	
58 (*)	2	Tappo	Plug	R 1/4" DIN 908	S			○	○	○	○	○			
					K									○	○
58.1 (**)	2	Guarnizione	Gasket	1/4"											
60 (*)	1	Ingrassatore	Grease nipple	1/4"	S			○	○	○	○	○	○	○	
64 (*)	2	Tappo	Plug	R 1/2" DIN 908	S			○	○		○	○			
	1				K								○	○	
64.1 (*)	1	Tappo	Plug	R 1/2" DIN 908	S			○	○	○	○	○			
					K								○	○	
65 (**)	2	Guarnizione	Gasket	1/2"											
65.1 (**)	1	Guarnizione	Gasket	1/2"											
66	1	Tenuta completa	Mechanical seal	N 55 WCT - FL		5919 4012	1000 8952				○				
				N 55 GCT - FL		5919 4011	1000 8951				○		○		
69	2	Paraolio	Oil seal			1408 6008	1000 1297	○	○		○	○	○	○	
75 (**)	1	Guarnizione	Gasket	106 x 154 x 0,5											
76	1	Guarnizione	Gasket	28 x 60 x 2	E3	3450 0258	1000 5595	⊗	⊗	⊗					
79	4	Vite	Screw	M 10 x 25 DIN 933	S	1478 4025	1000 1948	⊗	⊗	⊗	⊗	⊗			
	8			M 10 x 25 DIN 933	S	1478 4025	1000 1948	⊗	⊗	⊗	⊗	⊗			
	5			M 8 x 20 DIN 933	K	1478 5008	1000 2027						⊗	⊗	
80	1	Portabaderna (8)	Stuffing box (8)		G	3615 3011	1000 6160	○	○	○					
					GS	5615 3012	1000 8485	⊗	⊗	⊗					
					K	3615 5007	1000 6204						○		
		Portatenuta	Seal box		G	3615 3332	1001 7588				○	○			
					K		1001 7587							○	
80.1	4	Vite	Screw	M 10 x 35 DIN 933	S	1478 4027	1000 1950	○	○	○	○	○			
					K	1478 5029	1000 2045							○	○
					Prigioniero	Stud	M 10 x 25 DIN 938	S	1468 4007	1000 1824	⊗	⊗	⊗		
80.2	4	Dado	Nut	M 10 DIN 934	S	1420 4005	1000 1421	○	○	○	○	○			
					K	1420 5006	1000 1437							○	○
80.3	8	Prigioniero	Stud	M 16 x 40 DIN 938	S	1468 4017	1000 1831	⊗	⊗	⊗					
80.4	8	Dado	Nut	M 16 DIN 934	S	1420 4009	1000 1425	⊗	⊗	⊗					
80.5	1	Spina	Spring pin	4 x 20	H	1463 5007	1000 1784				○	○		○	
80.7	4	Prigioniero	Stud	M 12 x 30 DIN 938	S	1468 4010	1000 1827	⊗	⊗	⊗					
80.8	4	Dado	Nut	M 12 DIN 934	S	1420 4006	1000 1422	⊗	⊗	⊗					
80.9	1	Flangia	Flange	DN20 PN16 UNI 6093	S	3362 4001	1000 5132	⊗	⊗	⊗					
82	1	Oliatore	Oil lubricator	R 1/4" KLG 4	S	1444 0053	1000 1671				○	○		○	
				R 1/4"		1444 0055	1000 1672				⊗	⊗		⊗	
82.1	1	Curva	Elbow	R 1/4"	G	1601 3002	1000 2292				○	○		○	
82.3	3	Tappo	Plug	R 1/4" DIN 908	S	1671 4002	1000 2410				○	○			
					K	1671 5002	1000 2414							○	
82.4	3	Guarnizione	Gasket	1/4"	D	3450 0600	1000 5657				○	○		○	
(*)	1	Serie viterie	Set of screws				1001 5176	○	○		○	○			
							1001 5178			○					
							1001 5177							○	○
(**)	1	Serie guarnizioni	Set of gaskets				1001 4967	○	○		○	○	○	○	
							1001 4968			○					

**Note:**

- 1) Completo di tappi (58, 64) e guarnizioni (58.1, 65).
- 2) Completo di tappi (58), guarnizioni, (12.3, 58.1), prigionieri (48.1), flangia (12.1) e dadi (48.2).
- 3) Completo di prigionieri (46).
- 4) Completo di linguette (41, 42), ghiera (16.1) e rondella (16.2).
- 5) Completo di viti (43) e guarnizione (31.1).
- 6) Completo di tappo (64.1) e guarniz. (65.1).
- 7) Completo di prigionieri (46.1).
- 8) Completo di prigionieri (80.1, 80.3, 80.7), dadi (80.4, 80.8), flangia (80.9) e guarnizioni (75, 76).

- ① + R Corpo riscaldato
- ② + R1 Tenuta riscaldata
- ③ + R2 Coperchio riscaldato senza by-pass
- ④ + R2Y Coperchio riscaldato con by-pass
- ⑤ + O2 Oliatore da 140 ml in vetro
- ⑥ + Y Con by-pass
- ⑦ + YY Con doppio by-pass

**\* Materiali di costruzione**

A	= Alluminio
B	= Bronzo
AD10	= Bronzo AD10
D	= Guarnital o fibra
E3	= Centellen VS 3820
G	= Ghisa
GR	= Grafite
GS	= Ghisa sferoidale
GSH	= Ghisa sferoidale sulfonizzata
H	= Acciaio inox AISI 304
K	= Acciaio inox AISI 316
K5	= Acciaio inox SAF 2205
K9	= Acciaio inox AISI 329
R	= Rame
S	= Acciaio
SH	= Acciaio trattato
SHT	= Acciaio per alte temperature
T	= Acciaio cementato
T2	= Acciaio K110
TE	= Teflon

Ordinare il materiale indicando sempre la quantità, la denominazione, il codice del pezzo, il tipo ed il numero della pompa.

**Notes:**

- 1) Complete with plugs (58, 64) and gaskets (58.1, 65).
- 2) Complete with plugs (58), and gaskets (12.3, 58.1), studs (48.1), flange (12.1) and nuts (48.2).
- 3) Complete with studs (46).
- 4) Complete with keys (41, 42), sleeve (16.1) and washer (16.2).
- 5) Complete with screws (43) and gasket (31.1).
- 6) Compl. with plugs (64.1) and gaskets (65.1).
- 7) Complete with studs (46.1).
- 8) Complete with studs (80.1, 80.3, 80.7), nuts (80.4, 80.8), flange (80.9) and gaskets (75, 76).

- ① + R Heating jacket on casing
- ② + R1 Heating jacket on stuffing box
- ③ + R2 Heating jacket on cover without by-pass
- ④ + R2Y Heating jacket on cover with by-pass
- ⑤ + O2 With 140 ml glass oil lubricator
- ⑥ + Y With by-pass
- ⑦ + YY With double by-pass

**\* Construction materials**

150	= Aluminium
B	= Bronze
AD10	= AD10 Bronze
D	= Guarnital or fiber
E3	= Centellen VS 3820
G	= Cast iron
GR	= Graphite
GS	= Ductile cast iron
GSH	= Sulfured graphite cast iron
H	= AISI 304 stainless steel
K	= AISI 316 stainless steel
K5	= SAF 2205 stainless steel
K9	= AISI 329 stainless steel
R	= Copper
S	= Steel
SH	= Hardened steel
SHT	= Steel for high temperature
T	= Case hardened steel
T2	= K110 steel
TE	= Teflon

When ordering spares always indicate type and serial number of pump, quantity, part name, and number.